

Selecting the Correct Backset

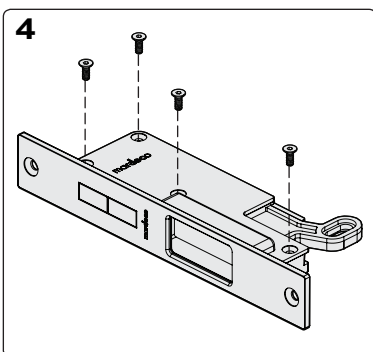

Contents Inside Package

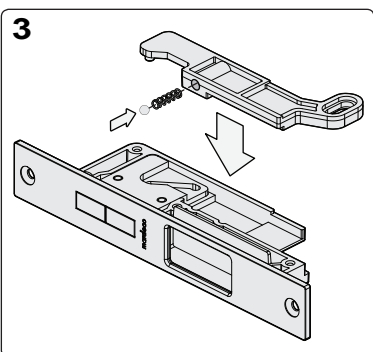
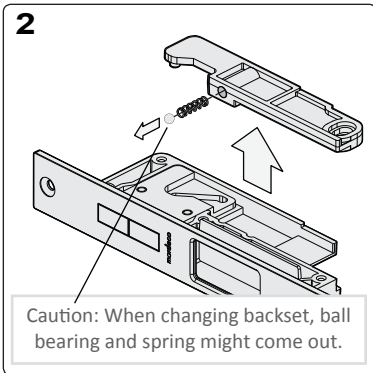
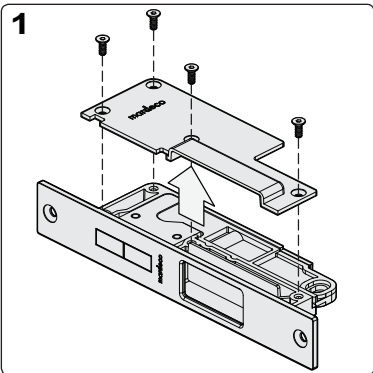
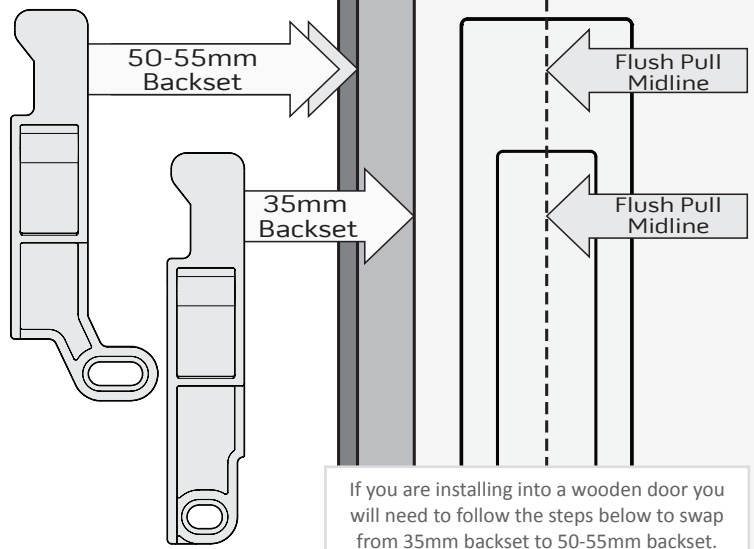
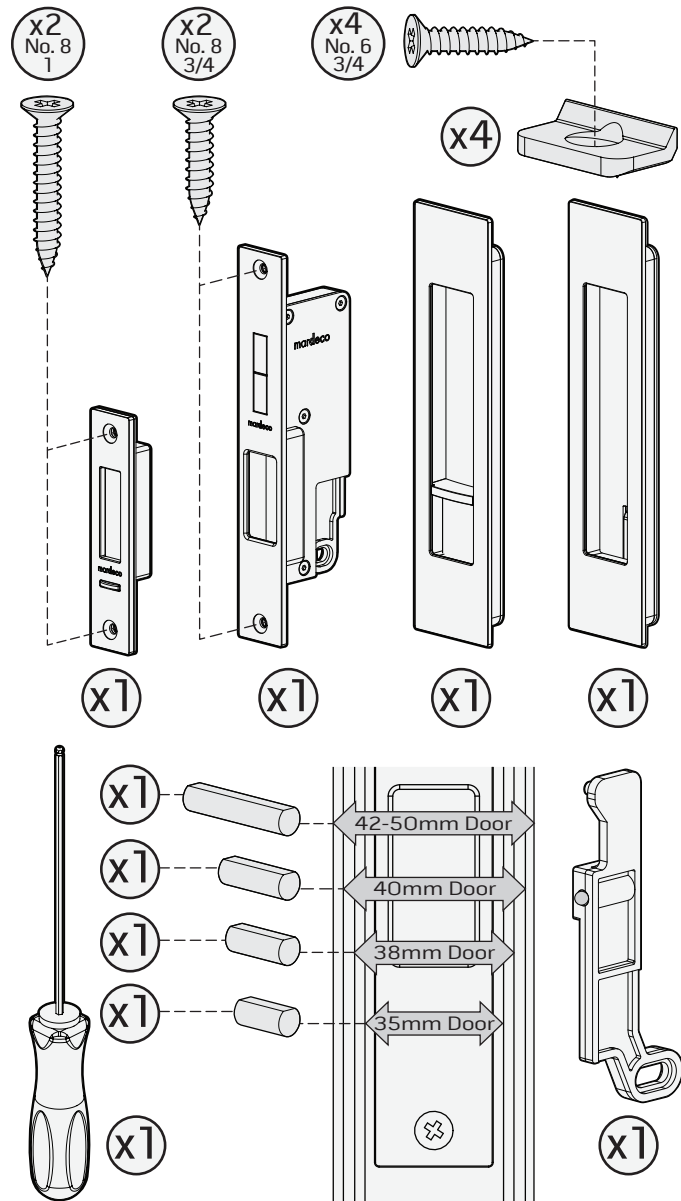

Please ensure you have received all the correct parts before installation. Mardeco International Ltd takes no responsibility for incorrect product being fitted.

Stainless Steel
Screws supplied by:
HECO
Germany



Flush Pull Privacy Set Installation Instructions

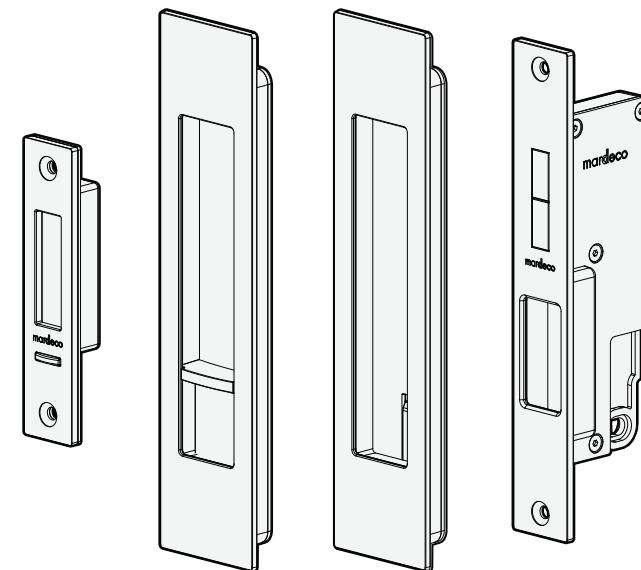

Mardeco International Ltd. retains the right to change products and specifications without notice.

Copyright © 2012 Mardeco International Ltd. All rights reserved. For full Terms & Conditions please visit our website.

www.mardeco.co.nz



Scan QR code to
view a step by step
installation video

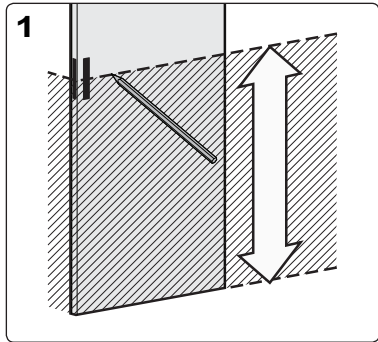

1 Mark midline on all 3 faces of the door. Choose a height that will be comfortable for all users to reach.

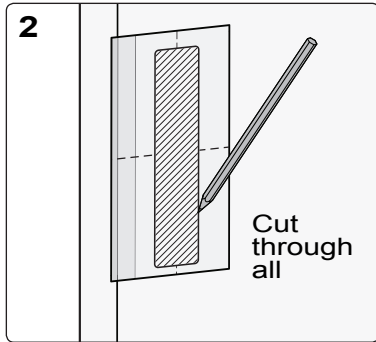

2 Wood Cutout: Remove middle section of flush pull template and mark cutout outline. Use midline as height reference. Mark for desired backset (35 or 50/55mm). Cut through all.

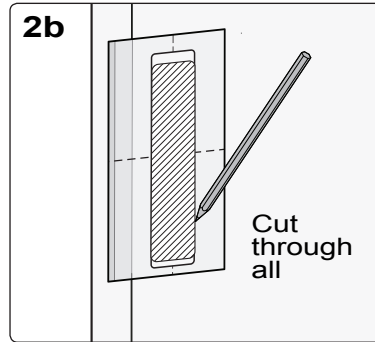

2b Aluminium Cutout: Match midline with template midline and position for desired backset. Mark aluminium cutout outline. Cut through all.

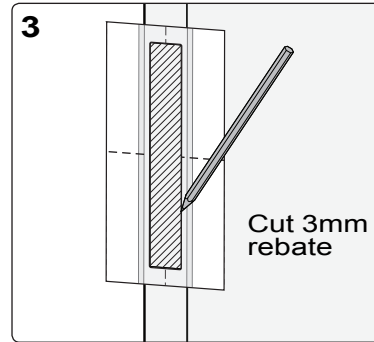

3 Remove middle section of end pull template and mark rebate outline on end of door. Use midline as height reference. Cut 3mm rebate.

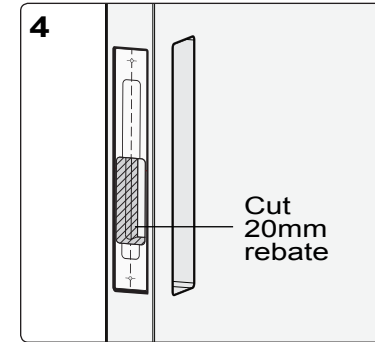

4 Place middle section of template into rebate and mark second rebate outline. Ensure it is the correct way up. Cut 20mm rebate

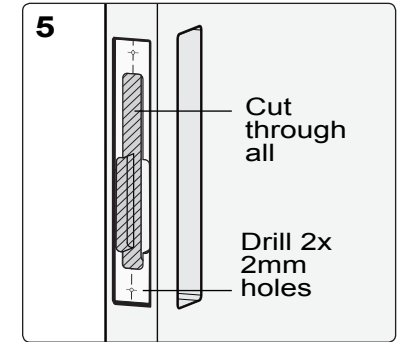

5 Mark the third rebate outline. Cut through into flush pull cavity. Mark screw hole locations. Drill two 2mm dia holes for the screws.

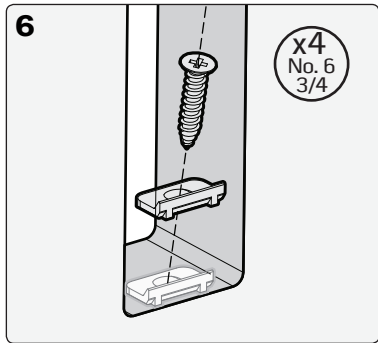

6 For wooden doors: install two woodfix brackets at top and bottom of cutout on both sides of the door.

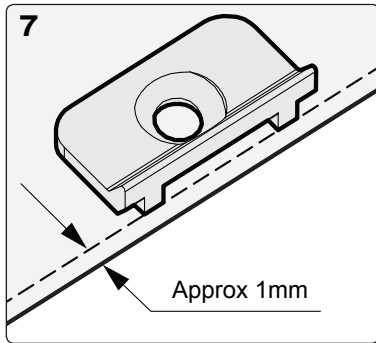

7 Fix brackets in centre of the cutout with the ridge facing outwards. Ensure that they are approx 1mm inside the edge and do not protrude.

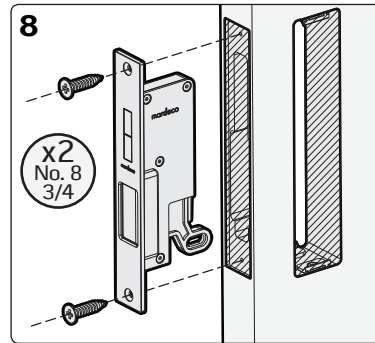

8 Insert the Privacy Lock assembly and secure with two No.8 3/4screws. Check lock is set up for the correct backset: see instructions for changing the backset.

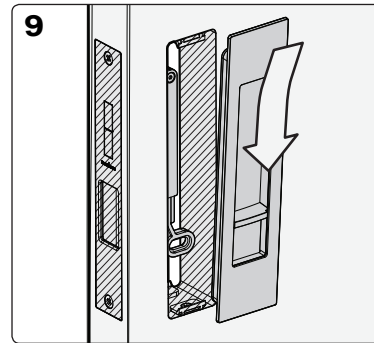

9 Insert the flush pull with the slide lock into cavity on the chosen side of the door. Push in and down so it grips onto the bottom bracket or edge.

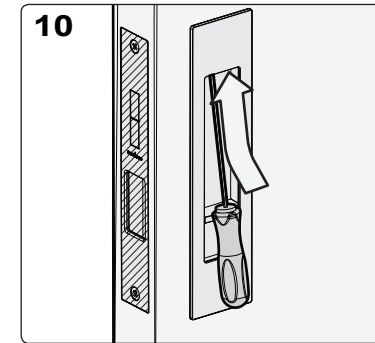

10 Use Mardeco hex tool to tighten grub screw inside top of flush pull. Ensure it is fitted firmly.

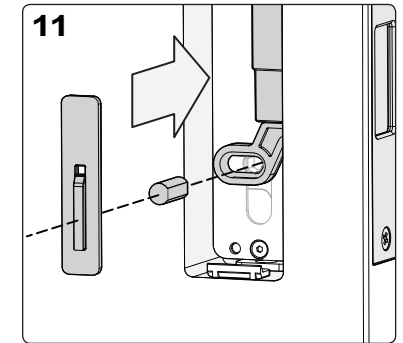

11 Insert spindle and emergency slide into the back of the lock slide. Choose the correct length spindle to suit your door thickness. Repeat steps 9 and 10 for installing the second flush pull.

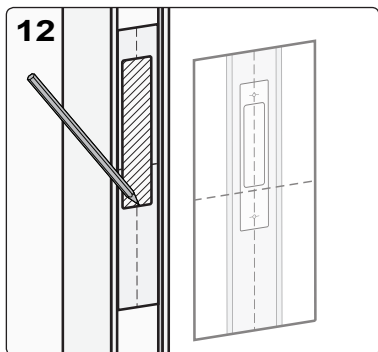

12 Remove middle section of striker plate template and mark outline for rebate. Use midline as height reference and ensure it lines up with the door. Cut a 4 mm rebate.

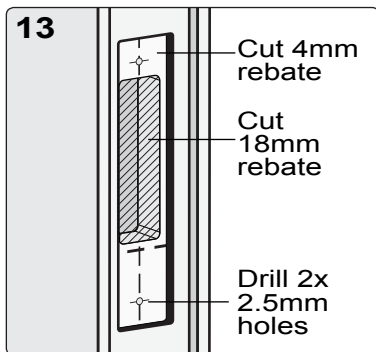

13 Place middle section of template into rebate and mark second rebate outline. Ensure it is the correct way up. Cut 18mm rebate. Mark screw holes and drill two 2mm holes 15mm deep.

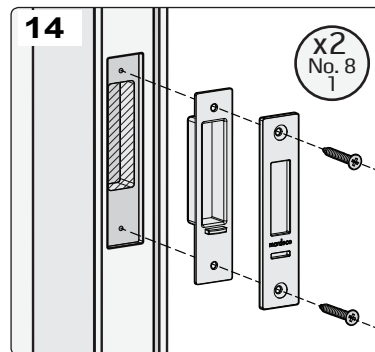

14 Insert striker plate assembly and secure with two No.8 1 screws.

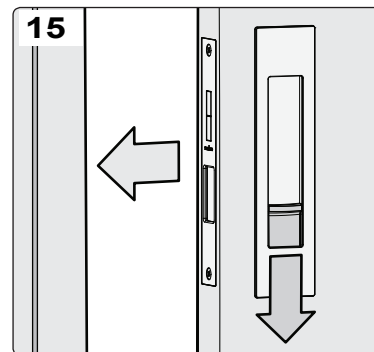

15 Test that everything works well and make any necessary adjustments. Enjoy using your new M Series Privacy Set.

Mardeco International Ltd.
PO Box 131
Whangaparaoa 0943
Auckland, New Zealand
Phone: +64 (0) 9 428 0658
Email: info@mardeco.co.nz
Web: www.mardeco.co.nz

mardeco[®]
international ltd
we handle the best